

SILICON NPN TRANSISTOR

■ SGS-THOMSON PREFERRED SALESTYPE

DESCRIPTION

The 2N5154 is a silicon epitaxial planar NPN transistors in Jedec TO-39 metal case intended for use in switching applications.

The complementary PNP type is the 2N5153.

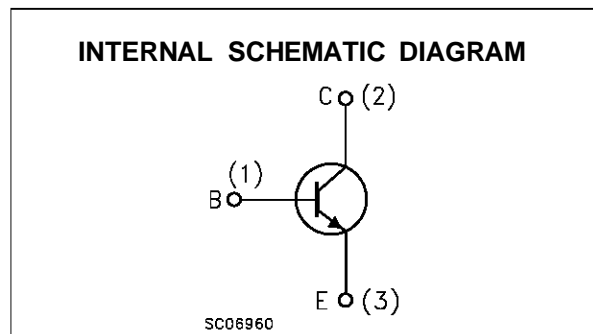
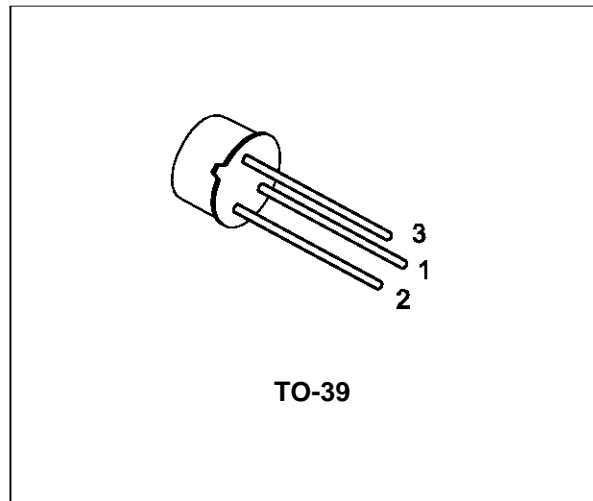

ABSOLUTE MAXIMUM RATINGS

Symbol	Parameter	Value	Unit
V_{CBO}	Collector-Base Voltage ($I_E = 0$)	100	V
V_{CEO}	Collector-Emitter Voltage ($I_B = 0$)	80	V
V_{EBO}	Emitter-Base Voltage ($I_C = 0$)	6	V
I_C	Collector Current	5	A
I_{CM}	Collector Peak Current	10	A
I_B	Base Current	1	A
P_{tot}	Total Dissipation at $T_c \leq 50\text{ }^\circ\text{C}$	10	W
P_{tot}	Total Dissipation at $T_c \leq 100\text{ }^\circ\text{C}$	6.7	W
P_{tot}	Total Dissipation at $T_{amb} \leq 25\text{ }^\circ\text{C}$	1	W
T_{stg}	Storage Temperature	-65 to 200	$^\circ\text{C}$
T_j	Max. Operating Junction Temperature	200	$^\circ\text{C}$

THERMAL DATA

R _{thj-case}	Thermal Resistance Junction-case	Max	15	°C/W
R _{thj-amb}	Thermal Resistance Junction-ambient	Max	175	°C/W

ELECTRICAL CHARACTERISTICS (T_{case} = 25 °C unless otherwise specified)

Symbol	Parameter	Test Conditions	Min.	Typ.	Max.	Unit
I _{CES}	Collector Cut-off Current (V _{BE} = 0)	V _{CE} = 60 V V _{CE} = 100 V			1 1	μA mA
I _{CEO}	Collector Cut-off Current (I _B = 0)	V _{CE} = 40 V			50	μA
I _{CEV}	Collector Cut-off Current (V _{BE} = -2V)	V _{CE} = 60 V T _C = 150 °C			500	μA
I _{EBO}	Emitter Cut-off Current (I _C = 0)	V _{EB} = 5 V V _{EB} = 6 V			1 1	μA mA
V _{CEO(sus)*}	Collector-Emitter Sustaining Voltage	I _C = 100 mA	80			V
V _{CE(sat)*}	Collector-Emitter Saturation Voltage	I _C = 2.5 A I _B = 250 mA I _C = 5 A I _B = 500 mA			0.75 1.5	V V
V _{BE(sat)*}	Base-Emitter Saturation Voltage	I _C = 2.5 A I _B = 250 mA I _C = 5 A I _B = 500 mA			1.45 2.2	V V
V _{BE*}	Base-Emitter Voltage	I _C = 2.5 A V _{CE} = 5 V			1.45	V
h _{FE*}	DC Current Gain	I _C = 50 mA V _{CE} = 5 V I _C = 2.5 A V _{CE} = 5 V I _C = 5 A V _{CE} = 5 V I _C = 2.5 A V _{CE} = 5 V T _C = -55 °C	50 70 40 35		200	
h _{FE}	Small Signal Current Gain	I _C = 0.1 A V _{CE} = 5 V f = 1KHz I _C = 0.5 A V _{CE} = 5 V f = 20MHz	50 3.5			
C _{CB0}	Collector-Base Capacitance	I _E = 0 V _{CB} = 10 V f = 1MHz			250	pF
t _{on}	Turn on Time	I _C = 5 A V _{CC} = 30 V I _{B1} = 0.5 A		0.5		μs
t _{off}	Turn off Time	I _C = 5 A V _{CC} = 30 V I _{B1} = -I _{B2} = 0.5A		1.3		μs

* Pulsed: Pulse duration = 300 μs, duty cycle 1.5 %

TO39 MECHANICAL DATA

DIM.	mm			inch		
	MIN.	TYP.	MAX.	MIN.	TYP.	MAX.
A	12.7			0.500		
B			0.49			0.019
D			6.6			0.260
E			8.5			0.334
F			9.4			0.370
G	5.08			0.200		
H			1.2			0.047
I			0.9			0.035
L	45° (typ.)					

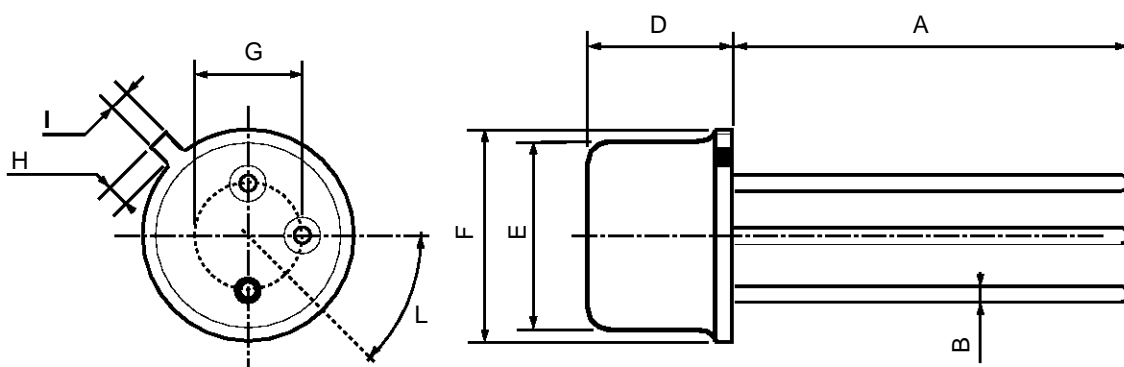

P008B

Information furnished is believed to be accurate and reliable. However, SGS-THOMSON Microelectronics assumes no responsibility for the consequences of use of such information nor for any infringement of patents or other rights of third parties which may result from its use. No license is granted by implication or otherwise under any patent or patent rights of SGS-THOMSON Microelectronics. Specifications mentioned in this publication are subject to change without notice. This publication supersedes and replaces all information previously supplied. SGS-THOMSON Microelectronics products are not authorized for use as critical components in life support devices or systems without express written approval of SGS-THOMSON Microelectronics.

© 1996 SGS-THOMSON Microelectronics - Printed in Italy - All Rights Reserved

SGS-THOMSON Microelectronics GROUP OF COMPANIES

Australia - Brazil - Canada - China - France - Germany - Hong Kong - Italy - Japan - Korea - Malaysia - Malta - Morocco - The Netherlands - Singapore - Spain - Sweden - Switzerland - Taiwan - Thailand - United Kingdom - U.S.A